



Brennilis Project

Background

Decontamination and Decommissioning of nuclear facilities can pose a number of challenges, including ensuring worker safety while operations are taking place and preventing the spread of contamination during the operation. To mitigate risk and maintain ALARA, the site is typically characterized and mapped in order to understand levels of contamination and to identify hot spots and contamination profiles at depths below the easily measured surface prior to dismantlement to remove historical unknowns.

Coring is a known method for evaluating the level of contamination that resides in the walls and floor of a building. With this method, a cylinder of material is removed from a hole that has been drilled to the core of the facility. Once the core is removed, it is generally cut up and taken to an offsite laboratory for analysis of the individual samples. While an accepted approach to D&D, there are several drawbacks to this method. Costly equipment is required to drill through to the core. The process of drilling, cutting the core and sampling can also be expensive and time consuming. Finally, cross-contamination can sometimes occur during the coring. This can occur as the drill bit travels down through contamination. The contamination can be carried down along the bit and dropped off at a different part of the core. The transfer of contamination during the coring process may make it appear that contamination is located in an area which is actually clean.

NMNT International, Inc. has developed the proprietary sampling and characterization technology called **TruPro**[®] to address the problems associated with traditional coring methods. The **TruPro** methodology collects all the drilled material as a representative and incremental sample. The method may be used for materials such as slabs, walls, concrete, glass, refractory block, granite, sand, dry soils and buried metal objects. The drilling is less invasive than coring, typically about a 12 mm hole as opposed to a 25–50 mm hole for most coring samples. With less invasive drilling, the time taken to obtain each sample is minimized, often from hours to minutes per sample. The material is removed from the hole as it is drilled and collected as individual incremental samples, eliminating cross contamination problems and minimizing secondary waste. Since the samples are smaller homogenized samples they are easier to quickly analyze using local laboratory equipment such as Liquid Scintillation Counters and as well as Gamma Spectroscopy Systems. This method results in time savings for the project, since the samples can be collected and counted quickly within 5–20 minutes of sample acquisition. Reduction in steps also means quicker feedback on contaminated areas, allowing the project team to prepare a detailed dismantlement plan and reduce exposure for workers.

For the customer to receive the full time savings and cost benefit of the **TruPro** technology, samples must be analyzed as they are collected on site. **NMNT International, Inc.** normally does the radioanalyses in-house but occasionally partners with nuclear measurement specialists to provide the gamma analysis for the **TruPro** samples. Partner selection may vary based on customer requirements, site requirements or type of samples that must be analyzed. With expertise in the field of nuclear measurements, we were selected by **NMNT International** to provide rental equipment as well as nuclear measurement services at the EDF Brennilis site, located in Brittany, France. At Brennilis, the Canberra™ ServiceS group offered expertise and innovative solutions that allowed the team to quickly overcome site challenges and accomplish nuclear measurement tasks on schedule and to the satisfaction of the customer.

Site requirements and challenges

The building undergoing decommissioning is the STE building (Service de Traitement des Effluents), where the liquid effluents are processed at the power station prior to being released. EDF selected **NMNT International** to perform the facility characterization because the **TruPro** method would allow EDF to assess the levels of contamination while still maintaining the integrity of the building. Concerns in maintaining the integrity of the site extended to sample analysis as well. To prevent the removal of dust from the site, samples were to remain within the STE building. **TruPro** samples were typically collected in 250 mL vials and by using portable calibrated radiometric instruments to analyze for Specific Radionuclide Activities of interest, Co-60, Cs-137, Eu-152, Eu-154, Eu-155, Pu-239, Am-241 and Pu-241. The **TruPro** method provided the ability to penetrate “hot” contaminated concrete with very dense subsurface rebar through layers of materials to depths of 10 cm to 2.5 meters, with 3 x 50 cm incremental samples of foundation subsurface granite and soil per deep location. This provided fine resolution to contamination distribution throughout the facility and also proved large volumes of concrete were “clean”. Discrete representative separate samples including 280 powdered concrete and granite samples from the facility structures were retrieved and in 21 days completely sampled and characterized within the facility, allowing EDF to strategize for facility demolition, waste segregation, waste packaging and waste shipment.

For the analysis of the **TruPro** samples, the team initially felt that the Mirion ISOCS™/LabSOCS™ system would be the appropriate choice for gamma measurement. The ISOCS system offers a number of unique advantages for performing gamma sample assay and is widely used in D&D projects. The complete system includes a rugged ISOCS cart, outfitted with ISOCS calibrated HPGe detectors, digital electronics, and ISOCS and LabSOCS analysis software. The team was

restricted from bringing sources on site, so use of an ISOCS calibrated detector was key since ISOCS calibrated detectors do not require sources for calibration. Additionally, powerful ISOCS software is designed to accommodate a wide range of geometries and densities, and this flexibility would be helpful in analyzing the **TruPro** samples.

Sample analysis in a rugged D&D environment can pose a unique set of problems, however, and the team determined that they were lacking sufficient space within the building to deploy the standard ISOCS system. Space constraints also made it impossible to put the container on the top of the detector – the detector would need to be positioned on its side. The team knew that ISOCS sourceless calibration would be an advantage, but they would not be able to deploy the traditional ISOCS cart configuration. The team finally selected a GC4020 coaxial detector with a big MAC portable multi-attitude cryostat. The unique orientation of the detector and sample also called for a specialized shielding to surround the detector body. The team quickly designed and procured the specialized lead shielding to accommodate this configuration.

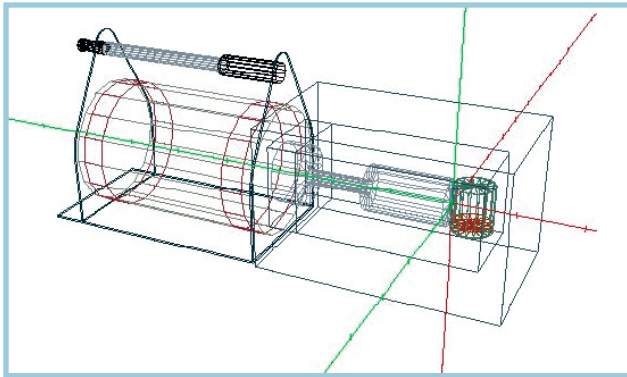

Measurement challenges

With the selection of equipment accomplished, the team moved forward to the next phase of the project. Measurement conditions remained a challenge as they began to drill and collect samples. In addition to the limited working space, the building was not in a good state of repair and had a provisional roof. The team immediately noticed the high radon background in the environment, due to local geology and other factors.

The ServiceS team is experienced in handling radon issues, and was able to compensate for this local phenomenon with Genie™ 2000 software. Using Genie 2000 background subtraction, the gamma spectroscopy system was able to distinguish the radon background from non-environmental factors. Natural background levels varied significantly each day, thus background measurement and subtraction became an important element of the project.

Another challenge was the collection of samples resulting from the **TruPro** drillings. While the **TruPro** technique produces samples for counting in a 250 mL vial, the actual amount of sample varied from vial to vial. Additionally, because of the space constraints, the samples were placed to the side of the detector, rather than on top of the detector. As a result, the uniformity of the powder at the bottom of the container varied, as did the density. Using the powerful capabilities of ISOCS software, the team was able to accommodate these changes by modeling a range of geometries. Geometries were created for 1.5 and 3 grams, and then for each 5 gram increment from 5 grams to 145 grams. With these models in place, they were able to accommodate the variations that occurred from sample to sample.

Results

With the conclusion of this project, the customer realized a number of benefits as a result of the **NMNT International / Mirion/Canberra** partnership. The **TruPro** technique reduced sampling time, while maintaining the integrity of the building. Without the traditional requirement for coring and external laboratory testing, the **NMNT International** and the Mirion teams worked on site in close proximity to one another. This close cooperation allowed them to quickly address technical challenges and develop solutions to move forward, actually improving the quality of the results.

With Genie 2000 analysis, QA and reporting tools the ServiceS team was able to generate comprehensive reports and provide immediate feedback on a daily basis. The reports detailed:

- Individual analysis of each sample
- Collective analysis of all samples
- Background and historical, with historical curve
- QA and historical, with historical curve
- New geometry

The excellent detection limits, as well as the immediate availability of the data and the accuracy of its results allowed the team to swiftly identify and further examine potential hot spots within the building. In all, 280 measurements were taken from the **TruPro** samples over approximately 21 working days. As a result of their work at Brennilis, **NMNT International** received an “A rating” from EDF, the highest rating offered to a vendor. The successful joint effort demonstrated that the Mirion solutions are well suited for analysis of **TruPro** samples. The companies are pursuing new opportunities to work together to provide added value for customers planning decontamination and decommissioning projects.

www.mirion.com