

LLWR-Uncompactable Waste Monitoring Service

Scope:

This project is to provide a Quality Assurance (QA) verification of consignors' waste declarations for LLW consigned to the LLWR repository in ISO containers. A High Resolution Gamma ray Spectrometry methodology has been developed using the In-Situ Object Counting System (ISOCST[™]) which is an established flexible tool for quantifying the β/γ activity content. This technique is based on computer modeling of the item under interrogation, in order to represent the counting geometry, with no requirement for radioisotope calibration sources. Measurements were performed at the Low Level Waste Repository (LLWR) in Cumbria, UK.

Key Drivers:

LLWR Ltd's key requirement is to verify that ISO containers meet the consignor's declared information. LLWR Ltd is developing the range of its services offered to clients. Its underlying objective is to ensure that waste is sentenced to the LLWR repository appropriately and to maximize utilization of the available space for storage of consignments.



Onsite measurements were conducted between 2009 and 2012.



Visit our Measurement and Expertise (M&E) page.



MIRION
TECHNOLOGIES

LLWR-Uncompactable Waste Monitoring Service

Case Study

Instruments & Techniques Used:

- 1 Instruments**
 - ISOCS
- 2 Software**
 - ISOCS modeling

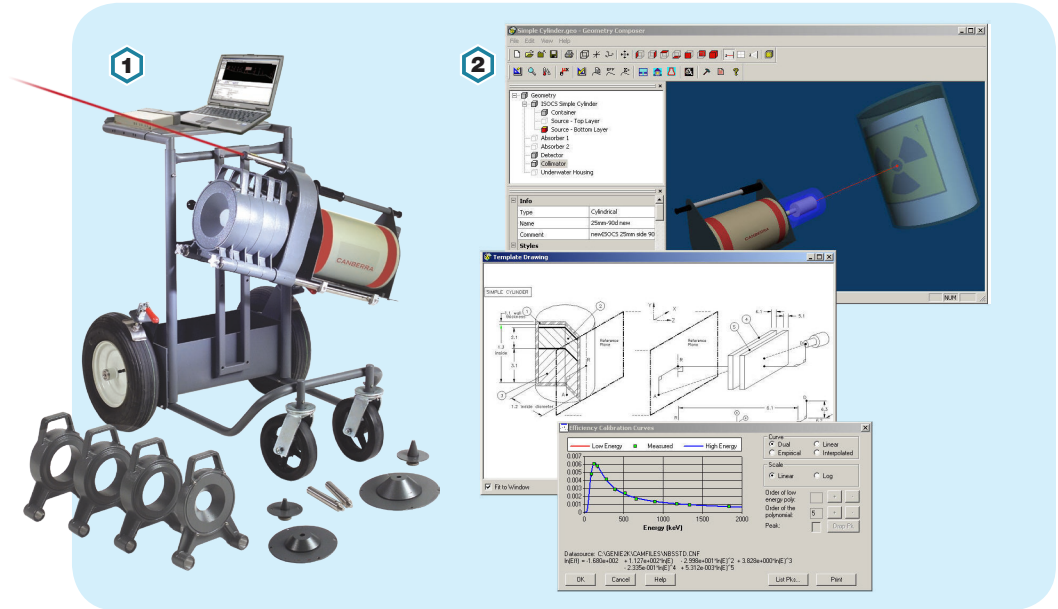

CANBERRA™ Solution:

In order to address LLWR Ltd's key objectives, a CANBERRA team developed a new technique for performing the quality check measurements on ISO containers, based on scanning measurements using portable High Resolution Gamma Spectrometry. The key elements of this solution are as follows:

- Development and validation of an ISO container assay methodology based on scanning measurements using a standard ISOCS system.
- Development of complete step by step procedures integrating our complete measurement process into LLWR Ltd's quality program.
- Verifying the system calibrations with actual QC standards
- ISOCS modeling of the ISO container for each container measurement, taking into account data from the consignors on the details of the waste composition.
- Identification of activity "hot spots" using dose rate measurements and, subsequently, modification of the standard analysis process where appropriate.
- Identification and quantification (with total measurement uncertainties) of customer required radionuclides.
- Identification of undeclared radionuclides (quoting Minimum Detectable Activities).
- Expert review of the measured activities in comparison with the declared values.
- Submission of a complete analysis report for each container measured, detailing the measurement and analysis procedure and the assumptions made in the analysis.

ACHIEVEMENTS

- The UK measurements team has helped the LLWR Ltd Service Assurance team to develop future strategies for the management and verification of LLW waste. The container measurements have provided valuable data for LLWR Ltd, contributing to a collective understanding of the nature of the challenges underlying assurance monitoring of bulk waste containers. This has led to improved identification of the data required from consignors to allow improved assurance monitoring, and has helped to improve LLWR Ltd's confidence in the waste consignment records.

Copyright ©2018 Mirion Technologies, Inc. or its affiliates. All rights reserved. Mirion, the Mirion logo, CANBERRA, ISOCS and other trade names of Mirion products listed herein are trademarks and/or registered trademarks of Mirion Technologies, Inc. and/or its affiliates in the United States and/or other countries.

Third party trademarks mentioned are the property of their respective owners.